









What do you need to bring to Kindy?

Below is a checklist of all the things you need to bring to Kindy, any questions please ask.

All items must be clearly labelled.

<p>Shady Hat</p> <ul style="list-style-type: none"> Legionnaire or wide brimmed 		<input type="checkbox"/>
<p>Backpack</p> <ul style="list-style-type: none"> Large enough to place all belongings in. Sometimes we find that bags are too small 		<input type="checkbox"/>
<p>Spare Clothes in a swim bag or similar draw string bag, including underwear</p> <ul style="list-style-type: none"> Please ensure they are season appropriate and the right size as well as clearly labelled with your child's name 		<input type="checkbox"/>
<p>Library Bag (Later in Term One)</p> <ul style="list-style-type: none"> Please ensure this is clearly labelled with your child's name (Library will commence once children are settled into our routine) 		<input type="checkbox"/>
<p>Sheet Set (available for purchase or instructions are overleaf)</p> <ul style="list-style-type: none"> Including top sheet and an elastic bottom sheet with exposed corners as per the pattern in the Family Handbook. Sheets will be sent home weekly to be laundered (a small blanket can be sent in winter) The pillow case you get in the sheet set can be used as the sheet bag 		<input type="checkbox"/>

Lunch Box Requirements

<p>Water Bottle (approx 500mls)</p>		<input type="checkbox"/>
<p>Morning Tea/Afternoon Tea for Lorikeet's only</p> <ul style="list-style-type: none"> Fruit/veggies/yoghurt/crackers/cheese etc 		<input type="checkbox"/>
<p>Lunch</p> <ul style="list-style-type: none"> Sandwiches/wraps/fruit/yoghurt 		<input type="checkbox"/>

Sheet Instructions

Two sheets—cut two pieces fabric, bottom sheet →143cm x 65cm and hem all round to a finished size of 139cm x 61cm, and top sheet →144cm x 85cm and hem all round to a finished size of 130cm x 81cm. To finish off the bottom sheet—Cut 1m of strong 2.5cm wide elastic into 4 x 25cm pieces. Affix elastic diagonally across each corner of the bottom sheet, stitching it to the side hem of the sheet 15cm from corner of fabric (as per diagram below to the left. See red dotted line.) Please reinforce the stitching over elastic, as this is an area of the sheets that often pulls away during the year. Final step —fold the four corners under on this bottom sheet onto wrong side of fabric and stitch flat. (please ask teachers for a demonstration)

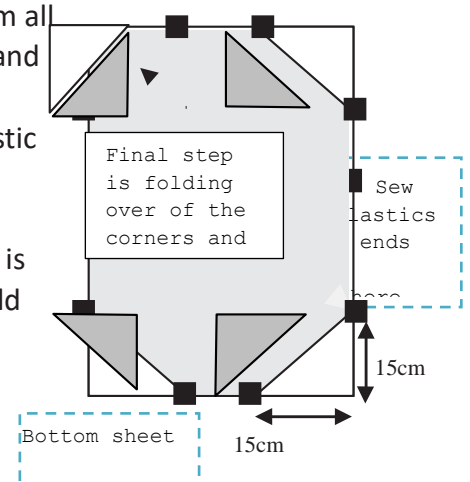

One sheet bag with drawstring approx. 50cm square.

A light blanket for winter is a good idea. **(Same size as sheet)** Some children feel more comfortable with a **small pillow**. Please no bigger than 30cm square. **Please ensure it can fit inside the sheet bag.**

Lunch box Information/Recommendations

- Food suggestions - Fruit, celery/carrot sticks, other suitable vegetables, sultanas, cheese, dates, prunes, tomatoes, rice cakes, rice crackers, pasta, etc or a mixture of these. Sandwich/Wraps meat, salad, cheese, vegemite.



- Please ensure your child is able to open their lunch box, containers and wrapping as we aim to limit handling of food by others and encourage self-reliance.
- Please provide a spoon if sending food that requires a spoon.
- If sending yoghurt please send it in a tub/container (that can be re-used), not the squeeze containers with lids as these are a choking hazard and children have trouble opening them.
- Please get your child to place their own food/containers and lunch box into the fridge so they are aware of what is theirs.
- Please do not bring any other food or drink, NO NUTS, cakes, chocolate bars or sweet biscuits. This is considered a sometimes food for home.
- Please try to limit pre-packaged food which is often filled with preservatives.